

SUMMARY OF PRODUCT CHARACTERISTICS

1 NAME OF THE MEDICINAL PRODUCT

Sodium pertechnetate (^{99m}Tc) CIS bio international 2-50 GBq radionuclide generator

2 QUALITATIVE AND QUANTITATIVE COMPOSITION

Sodium pertechnetate (^{99m}Tc) injection is produced by means of a ($^{99}\text{Mo}/^{99m}\text{Tc}$) generator. Technetium (^{99m}Tc) decays with the emission of gamma radiation with a mean energy of 140 keV and a half-life of 6.01 hours to technetium (^{99}Tc) which, in view of its long half-life of 2.13×10^5 years, can be regarded as quasi stable.

The radionuclide generator containing the parent isotope ^{99}Mo , adsorbed on a chromatographic column, delivers sodium pertechnetate (^{99m}Tc) injection in sterile solution.

The ^{99}Mo on the column is in equilibrium with the formed daughter isotope ^{99m}Tc . The generators are supplied with the following ^{99}Mo activity amounts at activity reference time which deliver the following technetium (^{99m}Tc) amounts,:

^{99m}Tc activity (Maximal eluable activity at calibration date, 12h CET)	2	4	6	8	10	12	16	20	25	50	GBq
^{99}Mo activity (at calibration date, 12h CET)	2.5	5	7	9.5	12	14.5	19	24	30	60	GBq

The technetium (^{99m}Tc) amounts available by a single elution depend on the real yields of the kind of generator used itself declared by manufacturer and approved by national Competent Authority.

Excipient with known effect:

Each mL of sodium pertechnetate (^{99m}Tc) solution contains 3.6 mg of sodium.

For the full list of excipients, see section 6.1.

3 PHARMACEUTICAL FORM

Radionuclide generator.

The solution eluted is a clear and colourless sodium pertechnetate (^{99m}Tc) solution, with a pH between 4.5 and 7.5.

4 CLINICAL PARTICULARS

4.1 Therapeutic indications

This medicinal product is for diagnostic use only.

The eluate from the radionuclide generator (sodiumpertechnetate (^{99m}Tc) injection) is indicated for:

- Labelling of various kits for radiopharmaceutical preparation developed and approved for radiolabelling with such solution.
- Thyroid scintigraphy: direct imaging and measurement of thyroid uptake to give information on the size, position, nodularity and function of the gland in case of thyroid disease.
- Salivary gland scintigraphy: diagnosis of chronic sialadenitis (e.g. (Sjögren's Syndrom) as well as assessment of salivary gland function and duct patency in salivary glands disorders and monitoring of the response to therapeutic interventions (in particular radio iodine therapy).
- Location of ectopic gastric mucosa (Meckel's diverticulum).
- Lacrimal duct scintigraphy to assess functional disorders of lacrimation and monitoring of the response to therapeutic interventions.

4.2 Posology and method of administration

Posology

If sodium pertechnetate (^{99m}Tc) is administered intravenously activities may vary widely according to the clinical information required and the equipment employed. The injection of activities greater than local DRLs (Diagnostic Reference Levels) should be justified.

Recommended activities are as follows:

Adults (70 kg) and elderly population:

- Thyroid scintigraphy: 20-80 MBq
- Salivary gland scintigraphy: 30 to 150 MBq for static images up to 370 MBq for dynamic images.
- Meckel's diverticulum scintigraphy: 300-400 MBq
- Lacrimal duct scintigraphy: 2-4 MBq per eye.

Renal impairment

Careful consideration of the activity to be administered is required since an increased radiation exposure is possible in these patients.

Paediatric population

The use in children and adolescents has to be considered carefully, based upon clinical needs and assessing the risk/benefit ratio in this patient group.

The activities to be administered to children and adolescents must be adapted and may be calculated according to the recommendations of the European Association of Nuclear Medicine (EANM) paediatric dosage card; the activity administered to children and to adolescents may be calculated by multiplying a baseline activity (for calculation purposes) by the weight-dependent correction factor given in the table below (see Table 1).

$$A[\text{MBq}]_{\text{Administered}} = \text{Baseline Activity} \times \text{Multiple}$$

Thyroid scintigraphy:

Activity administered [MBq] = 5.6 MBq x correction factor (Table 1),
 A minimal activity of 10 MBq is necessary for obtaining images of sufficient quality.

Identification/location of ectopic gastric mucosa:

Activity administered [MBq] = 10.5 MBq x correction factor (Table 1),
 A Minimal activity: 20 MBq is necessary in order to obtain images of sufficient quality.

Table 1: Weight-dependent correction factors in the paediatric population (for thyroid scintigraphy and identification/location of ectopic gastric mucosa) according to the EANM-May 2008 guidelines

Weight	factor	Weight	factor	Weight	factor
3 kg	= 1	22 kg	= 5.29	42 kg	= 9.14
4 kg	= 1.14	24 kg	= 5.71	44 kg	= 9.57
6 kg	= 1.71	26 kg	= 6.14	46 kg	= 10.00
8 kg	= 2.14	28 kg	= 6.43	48 kg	= 10.29
10 kg	= 2.71	30 kg	= 6.86	50 kg	= 10.71
12 kg	= 3.14	32 kg	= 7.29	52-54 kg	= 11.29
14 kg	= 3.57	34 kg	= 7.72	56-58 kg	= 12.00
16 kg	= 4.00	36 kg	= 8.00	60-62 kg	= 12.71
18 kg	= 4.43	38 kg	= 8.43	64-66 kg	= 13.43
20 kg	= 4.86	40 kg	= 8.86	68 kg	= 14.00

Salivary gland scintigraphy:

The Paediatric Task Group of EANM (1990) recommends that the activity to be administered to a child should be calculated from the body weight according to the table below (see Table 2) with a minimum dose of 10 MBq in order to obtain images of sufficient quality.

Table 2: Weight-dependent correction factor in the paediatric population (for salivary gland scintigraphy) according to EANM 1990 recommendations:

Weight	factor	Weight	factor	Weight	factor
3 kg	= 0.1	22 kg	= 0.50	42 kg	= 0.78
4 kg	= 0.14	24 kg	= 0.53	44 kg	= 0.80
6 kg	= 0.19	26 kg	= 0.56	46 kg	= 0.82
8 kg	= 0.23	28 kg	= 0.58	48 kg	= 0.85
10 kg	= 0.27	30 kg	= 0.62	50 kg	= 0.88
12 kg	= 0.32	32 kg	= 0.65	52-54 kg	= 0.90
14 kg	= 0.36	34 kg	= 0.68	56-58 kg	= 0.92
16 kg	= 0.40	36 kg	= 0.71	60-62 kg	= 0.96
18 kg	= 0.44	38 kg	= 0.73	64-66 kg	= 0.98
20 kg	= 0.46	40 kg	= 0.76	68 kg	= 0.99

Lacrimal duct scintigraphy:

Recommended activities apply as well for adults as for children.

Method of administration

For intravenous or ocular use

For multidose use.

For instructions on extemporaneous preparation of the medicinal product before administration, see section 12.

For patient preparation, see section 4.4.

In thyroid scintigraphy, salivary gland scintigraphy and identification/location of ectopic gastric mucosa, the sodium pertechnetate (^{99m}Tc) solution is administered by intravenous injection.

In lacrimal duct scintigraphy, drops are instilled in each eye (ocular use).

Image acquisition

Thyroid scintigraphy: 20 minutes after intravenous injection.

Salivary gland scintigraphy: immediately after intravenous injection and at regular intervals for 15 minutes.

Identification/location of ectopic gastric mucosa (Meckel's Diverticulum) immediately after intravenous injection and at regular intervals for 30 minutes.

Lacrimal duct scintigraphy: dynamic acquisition within 2 minutes after instillation, followed by static images acquired at regular intervals within 20 minutes.

4.3 Contraindications

Hypersensitivity to the active substance or to any of the excipients listed in section 6.1.

4.4 Special warnings and precautions for use

Potential for hypersensitivity or anaphylactic reactions

If hypersensitivity or anaphylactic reactions occur, the administration of the medicinal product must be discontinued immediately and intravenous treatment initiated, if necessary. To enable immediate action in emergencies, the necessary medicinal products and equipment such as endotracheal tube and ventilator must be immediately available.

Individual benefit/risk justification

For each patient, the radiation exposure must be justifiable by the likely benefit. The activity administered should in every case be as low as reasonably achievable to obtain the required diagnostic information.

Renal impairment

Careful consideration of the benefit risk ratio in these patients is required since an increased radiation exposure is possible.

Paediatric population

For information on the use in paediatric population, see section 4.2.

Careful consideration of the indication is required since the effective dose per MBq is higher than in adults (see section 11).

Thyroid blocking is of special importance in the paediatric patient population except for thyroid scintigraphy.

Patient preparation

Pre-treatment of patients with thyroid-blocking medicinal products may be necessary for certain indications.

The patient should be well hydrated before the start of the examination and urged to void as often as possible during the first hours after the examination in order to reduce radiation.

To avoid false positives or to minimize irradiation by reduction of pertechnetate accumulation in the thyroid and salivary glands, a thyroid blocking agent should be given prior to lacrimal duct scintigraphy or Meckel's diverticulum scintigraphy. Conversely a thyroid blocking agent must NOT be used before thyroid, parathyroid or salivary glands scintigraphy.

Before the application of sodium pertechnetate (^{99m}Tc) solution for scintigraphy of Meckel's diverticulum, the patient must keep an empty stomach for 3 to 4 hours to reduce intestinal peristalsis.

After in vivo labelling of erythrocytes using stannous ions for reduction sodium pertechnetate (^{99m}Tc) is primarily built into erythrocytes, therefore Meckel's diverticulum scintigraphy should be performed before or some days after in vivo labelling of erythrocytes.

After the procedure

Close contact with infants and pregnant women should be restricted during 12 hours.

Specific warnings

Sodium pertechnetate (^{99m}Tc) solution for injection contains 3.6 mg/mL of sodium.

Depending on the time when the injection is administered, the content of sodium given to the patient may in some cases be greater than 1 mmol (23 mg). This should be taken into account in patient on low sodium diet.

When sodium pertechnetate (^{99m}Tc) solution is used for labelling of a kit, the determination of the overall sodium content must take into account the sodium derived from the eluate and the kit. Please refer to the package leaflet of the kit.

In salivary gland scintigraphy a lower specificity of the method should be expected compared to magnetic resonance sialography.

For precautions with respect to environmental hazard see section 6.6.

4.5 Interaction with other medicinal products and other forms of interaction

Atropine, isoprenaline and analgesics may cause a delay of gastric emptying and thereby cause a redistribution of (^{99m}Tc) pertechnetate in abdominal imaging.

Administration of laxatives should be withheld since they irritate the gastrointestinal tract. Contrast-enhanced studies (e.g. barium) and upper gastro-intestinal examination should be avoided within 48 h prior to administration of pertechnetate (^{99m}Tc) for Meckel's diverticulum scintigraphy.

Many pharmacological medicinal products are known to modify the thyroid uptake:

- antithyroid medicinal products (e.g. carbimazole or other imidazole derivatives such as propylthiouracil), salicylates, steroids, sodium nitroprusside, sodium sulfobromophthalein, perchlorate should be withheld for 1 week prior thyroid scintigraphy;
- phenylbutazone and expectorants should be withheld for 2 weeks;
- natural or synthetic thyroid preparations (e.g. sodium thyroxine, sodium liothyronine, thyroid extract) should be withheld for 2-3 weeks;
- amiodarone, benzodiazepines, lithium should be withheld for 4 weeks;
- iodide contrast agents should not have been administered within 1-2 months.

4.6 Fertility, pregnancy and lactation

Women of childbearing potential

When an administration of radiopharmaceuticals to a woman of childbearing potential is intended, it is important to determine whether or not she is pregnant. Any woman who has missed a period should be assumed to be pregnant until proven otherwise. If in doubt about her potential pregnancy (if the woman has missed a period, if the period is very irregular, etc.), alternative techniques not using ionising radiation (if there are any) should be offered to the patient.

Pregnancy

Administration of pertechnetate (^{99m}Tc) to a woman who is known to be pregnant should be justified by medical need and a positive individual benefit risk assessment for the mother and the foetus. Alternative non-irradiation diagnostic modalities should be taken into account.

^{99m}Tc (as free pertechnetate) has been shown to cross the placental barrier.

Breast-feeding

Before administering radiopharmaceuticals to a mother who is breast-feeding, consideration should be given to the possibility of delaying the administration of radionuclide until the mother has ceased breast-feeding, and to what is the most appropriate choice of radiopharmaceuticals, bearing in mind the secretion of activity in breast milk. If the administration is considered necessary, breast-feeding should be interrupted for 12 hours post administration and the expressed feeds discarded.

Close contact with infants should be restricted during this period.

4.7 Effects on ability to drive and use machines

Sodium pertechnetate (^{99m}Tc) solution has no influence on the ability to drive and use machines.

4.8 Undesirable effects

Summary of the safety profile:

Information on adverse reactions is available from spontaneous reporting. The reported reaction types are anaphylactoid reactions, vegetative reactions, as well as different kinds of injection site reactions. Sodium pertechnetate (^{99m}Tc) from the Sodium pertechnetate (^{99m}Tc) CIS bio international radionuclide generator is used for radioactive labelling of a variety of compounds. These medicinal products generally have a higher potential for adverse reactions than ^{99m}Tc , and therefore the reported adverse reactions are rather related to the labelled compounds than to ^{99m}Tc . The possible types of adverse reactions following intravenous administration of a ^{99m}Tc -labelled pharmaceutical preparation will be dependent on the specific compound being used. Such information can be found in the SmPC of the kit used for radiopharmaceutical preparation.

Tabulated list of adverse reactions:

The frequency of undesirable effects is defined as follows:

Not known (cannot be estimated from the available data).

Immune system disorders

Frequency not known*: Anaphylactoid reactions (e.g. dyspnoea, coma, urticaria, erythema, rash, pruritus, oedema at various locations e.g. face oedema)

Nervous system disorders

Frequency not known*: Vasovagal reactions (e.g. syncope, tachycardia, bradycardia, dizziness, headache, vision blurred, flushing)

Gastrointestinal disorders

Frequency not known*: Vomiting, nausea, diarrhoea

General disorders and administration site conditions

Frequency not known*: Injection site reactions (e.g. cellulitis, pain, erythema, swelling)

* Adverse reactions derived from spontaneous reporting

Exposure to ionising radiation is linked with cancer induction and a potential for development of hereditary defects. As the effective dose is 5.2 mSv when the maximal recommended activity of 400 MBq is administered these adverse reactions are expected to occur with a low probability.

Description of selected adverse reactions

Anaphylactic reactions (e.g. dyspnoea, coma, urticaria, erythema, rash, pruritus, oedema at various locations [e.g. face oedema])

Anaphylactic reactions have been reported following intravenous injection of sodium pertechnetate (^{99m}Tc) and include various skin or respiratory symptoms like skin irritations, oedema, or dyspnoea.

Vegetative reactions (nervous system and gastrointestinal disorders)

Single cases of severe vegetative reactions have been reported, however, most of the reported vegetative reactions include gastrointestinal reactions like nausea or vomiting. Other reports include vasovagal reactions like headache or dizziness. Vegetative reactions are rather considered to be related to the examination setting than to technetium (^{99m}Tc), especially in anxious patients.

General disorders and administration site conditions

Other reports describe local injection site reactions. Such reactions are related to extravasation of the radioactive material during the injection, and the reported reactions rank from local swelling up to cellulitis. Depending on the administered radioactivity and the labelled compound, extended extravasation may necessitate surgical treatment.

Reporting of suspected adverse reactions

Reporting suspected adverse reactions after authorisation of the medicinal product is important. It allows continued monitoring of the benefit/risk balance of the medicinal product. Healthcare professionals are asked to report any suspected adverse reactions via

Yellow Card Scheme

Website: www.mhra.gov.uk/yellowcard or search for MHRA Yellow Card in the Google Play or Apple App Store

4.9 Overdose

In the event of administration of a radiation overdose with sodium pertechnetate (^{99m}Tc), the absorbed dose should be reduced where possible by increasing the elimination of the radionuclide from the body by defecation, forced diuresis and frequent bladder voiding.

The uptake in the thyroid, salivary glands and the gastric mucosa can be significantly reduced when sodium or potassium perchlorate is given immediately after an accidentally high dose of sodium pertechnetate (^{99m}Tc) was administered.

5 PHARMACOLOGICAL PROPERTIES

5.1 Pharmacodynamic properties

Pharmacotherapeutic group: diagnostic radiopharmaceuticals, various thyroid diagnostic radiopharmaceuticals, ATC code: V09 FX01.

No pharmacological activity has been observed in the range of doses administered for diagnostic purposes.

5.2 Pharmacokinetic properties

Distribution

The pertechnetate ion has similar biological distribution to iodide and perchlorate ions, concentrating temporarily in salivary glands, choroid plexus, stomach (gastric mucosa) and in the thyroid gland, from which it is eliminated, unchanged. The pertechnetate ion also tends to concentrate in areas with increased vascularisation or with abnormal vascular permeability, particularly when pre-treatment with blocking agents inhibits uptake in glandular structures. With intact blood brain barrier, sodium pertechnetate (^{99m}Tc) does not penetrate into the brain tissue.

Organ uptake

In the blood 70-80% of the intravenously injected sodium pertechnetate (^{99m}Tc) is bound to proteins, primarily in an unspecific way to albumin. The unbound fraction (20-30%) accumulates temporarily in thyroid and salivary glands, stomach and nasal mucous membranes as well as in the plexus chorioideus.

Sodium pertechnetate (^{99m}Tc) in contrast to iodine, nevertheless, is neither used for the thyroid hormone synthesis (organification), nor absorbed in the small intestine. In the thyroid the maximum accumulation, depending on functional status and iodine saturation (in euthyroidism approx. 0.3-3%, in hyperthyroidism and iodine depletion up to 25%) is reached about 20 min after injection and then decreases quickly. This also applies for the stomach mucous membrane parietal cells and the salivary glands acinar cells.

In contrast to the thyroid which releases sodium pertechnetate (^{99m}Tc) in the bloodstream the salivary gland and the stomach secrete sodium pertechnetate (^{99m}Tc) in the saliva and gastric juice respectively. The accumulation by the salivary gland lies in the magnitude of 0.5% of the applied activity with the maximum reached after about 20 minutes. One hour after injection the concentration in the saliva is about 10-30 fold higher than in the plasma. The excretion can be accelerated by lemon juice or by stimulation of the parasympathetic nerve system, the absorption is reduced by perchlorate.

Elimination

Half-life in plasma of approximately 3 hours. Sodium pertechnetate (^{99m}Tc) is not metabolised in the organism. One fraction is eliminated very quickly renally, the rest more slowly via faeces, salivary and tear liquid. Excretion during the first 24 hours following administration is mainly urinary (approximately 25%) with faecal excretion occurring over the next 48 hours. Approximately 50% of the administered activity is excreted within the first 50 hours. When selective uptake of pertechnetate (^{99m}Tc) in glandular structures is inhibited by the pre-administration of blocking agents, excretion follows the same pathways but there is a higher renal clearance.

The above data are not valid when sodium pertechnetate (^{99m}Tc) is used for labelling of another radiopharmaceutical.

5.3 Preclinical safety data

There is no information on acute, subacute and chronic toxicity from single or repeated dose administration. The quantity of sodium pertechnetate (^{99m}Tc) administered during clinical diagnostic procedures is very small and apart from allergic reactions, no other adverse reactions have been reported.

This medicinal product is not intended for regular or continuous administration.

Mutagenicity studies and long-term carcinogenicity studies have not been carried out.

Reproductive toxicity:

Placental transfer of ^{99m}Tc from intravenously administered sodium pertechnetate (^{99m}Tc) has been studied in mice. The pregnant uterus was found to contain as much as 60% of the injected ^{99m}Tc when administered without perchlorate pre-administration. Studies performed on pregnant mice during gestation, gestation and lactation, and lactation alone showed changes in progeny which included weight reduction, hairlessness and sterility.

6 PHARMACEUTICAL PARTICULARS

6.1 List of excipients

- Column system:

Aluminium oxide.

- Bag of solution for elution:

Sodium chloride, sodium nitrate, water for injection.

6.2 Incompatibilities

This medicinal product must not be mixed with other medicinal products except those mentioned in section 12.

6.3 Shelf life

Generator: 21 days from manufacturing date.

The calibration date and the expiry date are stated on the label.

Sodium pertechnetate (^{99m}Tc) eluate: After elution, use within 10 hours up to 10 withdrawals.

This medicinal product does not require any special storage conditions.

Elution vials: 24 months.

6.4 Special precautions for storage

Generator: This medicinal product does not require any special storage conditions.

Eluate: For storage conditions after elution of the medicinal product, see section 6.3.

Vacuum vials: Do not store above 25°C.

Storage of radiopharmaceuticals should be in accordance with national regulation on radioactive materials.

6.5 Nature and contents of container

Sodium pertechnetate (^{99m}Tc) CIS bio international generator is delivered in a type A transport container. It comprises:

- a 250 mL soft polypropylene bag containing the elution solution (1). It is connected by a stainless steel needle (2) to the top of the chromatographic column;
- a glass chromatographic column (3) closed at both ends by silicone stoppers filled with sintered stainless steel frits (4). This column contains alumina onto which molybdenum-99 is adsorbed.
- an outlet needle (5) connected to the bottom of the column, while the other end of the needle (6) can be connected to an elution vial to elute the column or a protective vial (STE-ELU) to maintain sterility between two elutions.

The alumina column and needle are protected by cylindro-conical lead or tungsten shielding (7). Generators up to 25 GBq of technetium (^{99m}Tc) are protected by lead shielding and that 50 GBq generators are protected by tungsten shielding.

The entire system is placed in a moulded plastic parallelepiped shell (23 x 21 x 14 cm) (8-9).

The elution needle emerges from the upper part of the plastic shell, protected by a transport cap or protective vial (STE-ELU).

A safety valve (10), closed during transport, is situated next to the elution needle.

Accessories supplied with the generator:

- a bag of 7 sterile, pyrogen-free, partial-vacuum elution vials (TC-ELU-5) (11) allowing the elution of 5 mL to 6 mL.
- a sterile elution needle protective vial (STE-ELU). Each elution vial or protective vial is a 15 mL, colourless, European Pharmacopoeia type I glass vial closed by a rubber stopper and sealed by an aluminium cap.
- an elution container (12) is provided with the first shipment.

Other accessories available:

- kits containing 7 x 15 mL vials:
 - partial vacuum vials allowing elution of 5 to 6 mL ;
 - partial vacuum vials allowing elution of 9 to 11 mL ;
 - vacuum vials allowing elution of 14 to 16 mL.
- additional lead shielding adapted to the Sodium pertechnetate (^{99m}Tc) CIS bio international generator: PROTECT ELU.

Packsize:

^{99m}Tc activity	2	4	6	8	10	12	16	20	25	50	GBq
(Maximal eluable activity at calibration date, 12h CET)											
^{99}Mo activity	2.5	5	7	9.5	12	14.5	19	24	30	60	GBq
(at calibration date, 12h CET)											

Diagram of the Sodium pertechnetate (^{99m}Tc) CIS bio international generator in elution mode

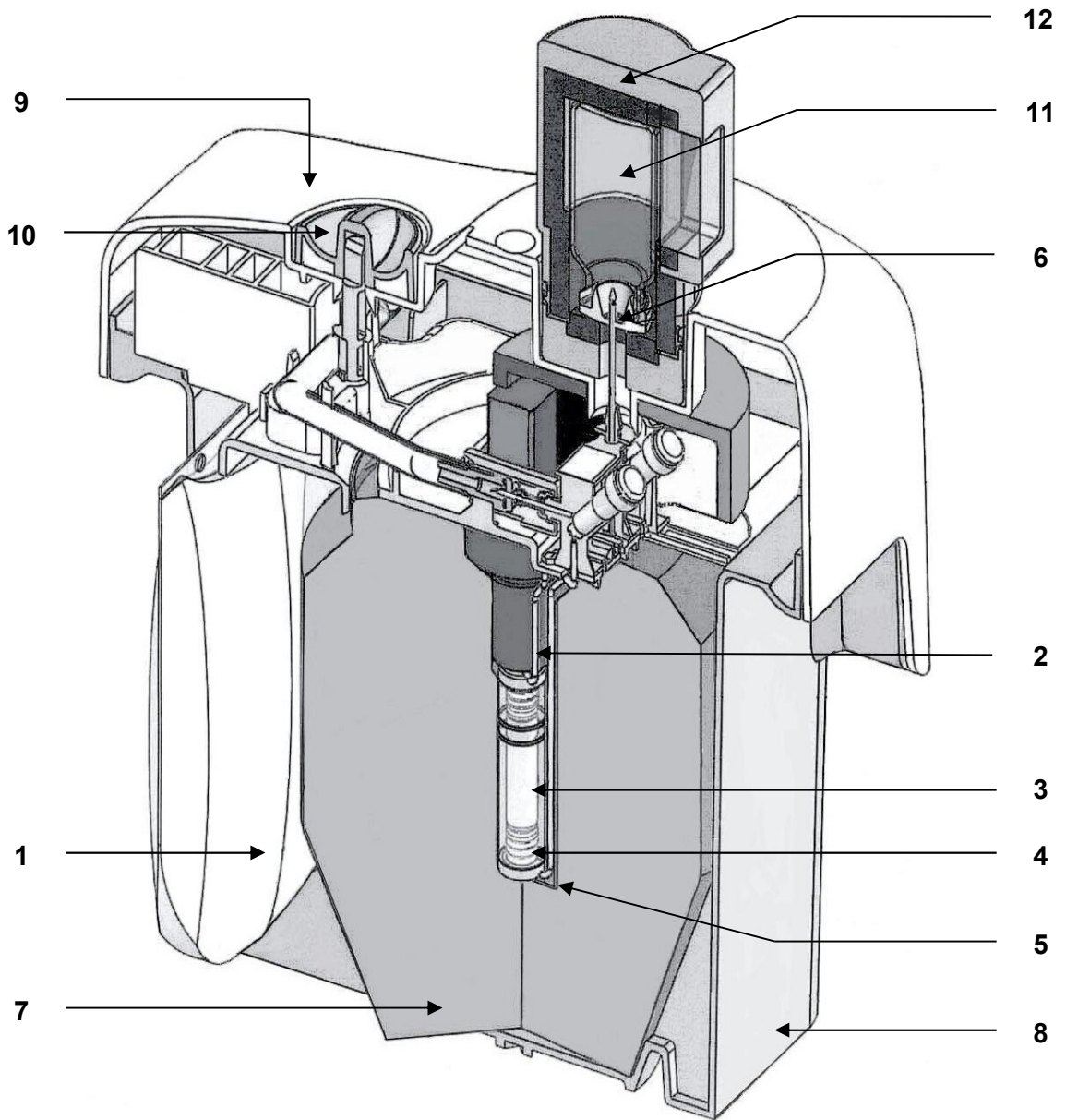

- | | | | |
|----------|--|--|-----------|
| 1 | bag of elution solution | cylindro-conical lead or tungsten shielding | 7 |
| 2 | connection needle | lower plastic shell | 8 |
| 3 | glass chromatography column | upper plastic shell | 9 |
| 4 | silicone stopper + sintered stainless steel frits | safety valve | 10 |
| 5 | stainless steel outlet needle | elution vial | 11 |
| 6 | elution needle | elution container | 12 |

6.6 Special precautions for disposal

General warnings

Radiopharmaceuticals should be received, used and administered only by authorised persons in designated clinical settings. Their receipt, storage, use, transfer and disposal are subject to the regulations and/or appropriate licences of the competent official organisation.

Radiopharmaceuticals should be prepared in a manner which satisfies both radiation safety and pharmaceutical quality requirements. Appropriate aseptic precautions should be taken.

If at any time the integrity of the generator or the vial with the eluted solution is compromised it should not be used.

Administration procedures should be carried out in a way to minimize risk of contamination of the medicinal product and irradiation of the operators. Adequate shielding is mandatory.

The administration of radiopharmaceuticals creates risks for other persons from external radiation or contamination from spills of urine, vomiting, etc. Radiation protection precautions in accordance with national regulations must therefore be taken.

The residual activity of the generator must be estimated before disposal.

Any unused medicinal product or waste material should be disposed of in accordance with local requirements.

7 MARKETING AUTHORISATION HOLDER

CIS bio international
B.P. 32
F-91192 GIF-SUR-YVETTE CEDEX

8 MARKETING AUTHORISATION NUMBER(S)

PL 11876/0022

9 DATE OF FIRST AUTHORISATION/RENEWAL OF THE AUTHORISATION

Date of first authorisation: 30th September 2011

Date of latest renewal: 15th June 2018

10 DATE OF REVISION OF THE TEXT

08/2024

11. DOSIMETRY

The data listed below are from ICRP 80 and are calculated according to the following assumptions:

(I) Without pre-treatment with a blocking agent:

Organ	Absorbed dose per administered unit of activity (mGy/MBq)				
	Adults	15 years	10 years	5 years	1 year
Adrenal glands	0.0037	0.0047	0.0072	0.011	0.019
Bladder wall	0.018	0.023	0.030	0.033	0.060
Bone surfaces	0.0054	0.0066	0.0097	0.014	0.026
Brain	0.0020	0.0025	0.0041	0.0066	0.012
Breasts	0.0018	0.0023	0.0034	0.0056	0.011
Gallbladder	0.0074	0.0099	0.016	0.023	0.035
Gastrointestinal tract					
- Stomach wall	0.026	0.034	0.048	0.078	0.16
- Small intestine	0.016	0.020	0.031	0.047	0.082
- Colon	0.042	0.054	0.088	0.14	0.27
- Ascending colon wall	0.057	0.073	0.12	0.20	0.38
- Descending colon wall	0.021	0.028	0.045	0.072	0.13
Heart	0.0031	0.0040	0.0061	0.0092	0.017
Kidneys	0.0050	0.0060	0.0087	0.013	0.021
Liver	0.0038	0.0048	0.0081	0.013	0.022
Lungs	0.0026	0.0034	0.0051	0.0079	0.014
Muscles	0.0032	0.0040	0.0060	0.0090	0.016
Oesophagus	0.0024	0.0032	0.0047	0.0075	0.014
Ovaries	0.010	0.013	0.018	0.026	0.045
Pancreas	0.0056	0.0073	0.011	0.016	0.027
Red bone marrow	0.0036	0.0045	0.0066	0.0090	0.015
Salivary glands	0.0093	0.012	0.017	0.024	0.039
Skin	0.0018	0.0022	0.0035	0.0056	0.010
Spleen	0.0043	0.0054	0.0081	0.012	0.021
Testes	0.0028	0.0037	0.0058	0.0087	0.016
Thymus	0.0024	0.0032	0.0047	0.0075	0.014
Thyroid	0.022	0.036	0.055	0.12	0.22
Uterus	0.0081	0.010	0.015	0.022	0.037
Other tissue	0.0035	0.0043	0.0064	0.0096	0.017
Effective dose (mSv/MBq)	0.013	0.017	0.026	0.042	0.079

(II) With pre-treatment with a blocking agent:

Organ	Absorbed dose per administered unit of activity (mGy/MBq) when blocking agents are administered				
	Adults	15 years	10 years	5 years	1 year
Adrenal glands	0.0029	0.0037	0.0056	0.0086	0.016
Bladder wall	0.030	0.038	0.048	0.050	0.091
Bone surfaces	0.0044	0.0054	0.0081	0.012	0.022
Brain	0.0020	0.0026	0.0042	0.0071	0.012
Breasts	0.0017	0.0022	0.0032	0.0052	0.010
Gallbladder	0.0030	0.0042	0.0070	0.010	0.013
Gastrointestinal tract					
- Stomach wall	0.0027	0.0036	0.0059	0.0086	0.015
- Small intestine	0.0035	0.0044	0.0067	0.010	0.018
- Colon	0.0036	0.0048	0.0071	0.010	0.018
- Ascending colon wall	0.0032	0.0043	0.0064	0.010	0.017
- Descending colon wall	0.0042	0.0054	0.0081	0.011	0.019
Heart	0.0027	0.0034	0.0052	0.0081	0.014
Kidneys	0.0044	0.0054	0.0077	0.011	0.019
Liver	0.0026	0.0034	0.0053	0.0082	0.015
Lungs	0.0023	0.0031	0.0046	0.0074	0.013
Muscles	0.0025	0.0031	0.0047	0.0072	0.013
Oesophagus	0.0024	0.0031	0.0046	0.0075	0.014
Ovaries	0.0043	0.0054	0.0078	0.011	0.019
Pancreas	0.0030	0.0039	0.0059	0.0093	0.016
Red bone marrow	0.0025	0.0032	0.0049	0.0072	0.013
Skin	0.0016	0.0020	0.0032	0.0052	0.0097
Spleen	0.0026	0.0034	0.0054	0.0083	0.015
Testes	0.0030	0.0040	0.0060	0.0087	0.016
Thymus	0.0024	0.0031	0.0046	0.0075	0.014
Thyroid	0.0024	0.0031	0.0050	0.0084	0.015
Uterus	0.0060	0.0073	0.011	0.014	0.023
Other tissue	0.0025	0.0031	0.0048	0.0073	0.013
Effective dose (mSv/MBq)	0.0042	0.0054	0.0077	0.011	0.019

The effective dose resulting from the intravenous administration of 400 MBq of sodium pertechnetate (^{99m}Tc) to an adult weighing 70 kg is about 5.2 mSv.

After pre-treatment of patients with a blocking agent and administration of 400 MBq of sodium pertechnetate (^{99m}Tc) to an adult weighing 70 kg the effective dose is 1.7 mSv.

The radiation dose absorbed by the lens of the eye following administration of sodium pertechnetate (^{99m}Tc) for lacrimal duct scintigraphy is estimated to be 0.038 mGy/MBq. This results in an effective dose equivalent of less than 0.01 mSv for an administered activity of 4 MBq.

The specified radiation exposure is only applicable if all organs accumulating sodium pertechnetate (^{99m}Tc) will function normally. Hyper/hypofunction (e.g. of the thyroid, gastric mucosa or kidney) and extended processes with impairment to the blood-brain-barrier or renal elimination disorders, may result in changes to the radiation exposure, locally even in strong increases of it.

External radiation exposure

	^{99}Mo - ^{99m}Tc dose rate on the surface of generator ($\mu\text{Sv/h.GBq}$)	^{99}Mo - ^{99m}Tc dose rate at 1 m distance from the generator ($\mu\text{Sv/h.GBq}$)
Shielding with 41 mm lead	16	0.3

The surface dose rates and the accumulated dose depends on many factors. Overall, radiation measurement on the environment and during work are critical and should be practised.

12 INSTRUCTIONS FOR PREPARATION OF RADIOPHARMACEUTICALS (IF APPLICABLE)

Elution of the generator must be performed in premises complying with the national regulations concerning the safety of use of radioactive products.

The solution eluted is a clear and colourless sodium pertechnetate (^{99m}Tc) solution, with a pH between 4.5 and 7.5 and a radiochemical purity equal to or greater than 95%.

When sodium pertechnetate (^{99m}Tc) solution is used for kit labelling, please refer to the package leaflet of the concerned kit.

Method of preparation

Disinfect the stopper of elution vials before each elution.

Warning:

Do not use ethanol or ethyl ether to disinfect the stopper of the elution vial, as this may interfere with the elution process.

During transport, sterility of the elution needle is ensured by a cap.

Protect the elution needle from possible bacterial contamination by placing the protective vial over the needle between two elutions.

Observe the following sequences to obtain satisfactory results:

First elution:

When using the generator for the first time, OPEN the safety valve (10) to the **ON** position BEFORE connecting the elution vial. Never close the safety valve between two elutions. Only close the safety valve at the time of disposal of the generator.

To elute the generator, replace the cap or protective vial by the elution container (A) containing a vacuum elution vial (labelled "TC-Elu") corresponding to the desired elution volume (13).

Elution can be observed through the lead glass window (14) of the container (A). Wait two minutes to ensure complete elution.

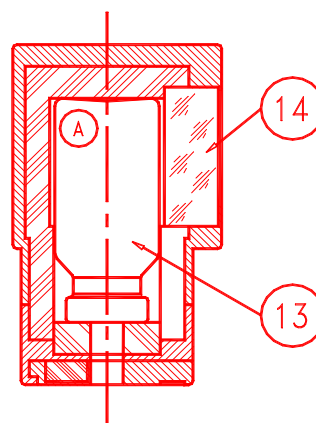

Check the clarity of the eluate before use and discard it if the solution is not clear.

After elution, immediately replace the protective vial to maintain sterility of the needle.

Elution volumes

Sodium pertechnetate (^{99m}Tc) CIS bio international is a generator designed to elute all of the available technetium-99m activity in a volume of 5 mL. Fractionated elutions are therefore unnecessary. However, elution to larger volumes can be performed: 10 mL or 15 mL.

Possibilities of use

The activity stated on the label of the generator is expressed in technetium-99m available at the calibration date (12:00 CET).

The available technetium-99m activity depends on:

- the molybdenum-99 activity at the time of elution;
- the time since the last elution.

Quality control

Radioactivity and the molybdenum-99 break-through must be checked before administration.

The test for molybdenum- (^{99}Mo) break-through can be performed either according to Ph. Eur. or to any other validated methods able to determine a molybdenum- (^{99}Mo) content below 0.1 per cent of total radioactivity at the date and hour of administration.

Mass of technetium ($^{99m}\text{Tc} + ^{99}\text{Tc}$) present in the eluate:

Molybdenum-99 is transformed into technetium-99m (87.6% of molybdenum-99 disintegrations) and technetium-99 (12.4% of the molybdenum-99 disintegrations). The total mass of technetium (^{99m}Tc) + (^{99}Tc) expressed in μg of technetium present in the eluate can be calculated by the following simplified formula:

$$M(\mu\text{g}) = \frac{\text{Technetium-99m activity of the eluate} \times k}{F}$$

$k = 5.161 \cdot 10^{-3}$ (activity expressed in GBq)

F is the ratio between the number of technetium-99m (N_{99m}) atoms and the total number of technetium atoms (N_t):

$$F = \frac{N_{99m}}{N_t}$$

The values of this ratio (F) as a function of the interval between two elutions are presented in the following table:

Hours	Days						
	0	1	2	3	4	5	6
0	-	0.277	0.131	0.076	0.0498	0.0344	0.0246
3	0.727	0.248	0.121	0.072	0.0474	0.0329	0.0236
6	0.619	0.223	0.113	0.068	0.0452	0.0315	0.0227
9	0.531	0.202	0.105	0.064	0.0431	0.0302	0.0218
12	0.459	0.184	0.098	0.061	0.0411	0.0290	0.0210
15	0.400	0.168	0.092	0.058	0.0393	0.0278	0.0202
18	0.352	0.154	0.086	0.055	0.0375	0.0266	0.0194
21	0.311	0.141	0.081	0.052	0.0359	0.0256	0.0187

Examples:

The technetium-99m of a generator is eluted into 5 mL; the measured activity is 10 GBq; the previous elution was performed 27 hours earlier.

The mass of technetium is:

$$M(\mu\text{g}) = \frac{10 \times 5.161 \cdot 10^{-3}}{0.248} = 0.208 \mu\text{g}$$

i.e.: 0.042 $\mu\text{g}/\text{mL}$

The technetium-99m of a generator is eluted 4 days after preparation (corresponding to the first elution). For an activity of 10 GBq eluted into 5 mL, the mass of technetium is:

$$M(\mu\text{g}) = \frac{10 \times 5.161 \cdot 10^{-3}}{0.0498} = 1.036 \mu\text{g}$$

i.e.: 0.207 µg/mL, i.e. five times more technetium than in the previous example. Although small, this amount of technetium may affect the labelling yield of some compounds.

The first eluate obtained from this generator can be normally used, unless otherwise specified.

Eluates even eluted later than 24 hours from the last elution can be used for kit labelling, unless it is excluded by the specifications of the relevant kit SmPC.

Any unused medicinal product or waste material should be disposed of in accordance with local requirements.

Detailed information on this medicinal product is available on the website of MHRA <http://www.mhra.gov.uk>.